

TR Złączka trójkątna redukcyjna

Końcówki EO
ze stożkiem 24°

Kształt korpusu stal i mosiądz (S1)
Szereg LL 4-8 mm D1, D2, D3
Szereg L 6+8 mm D1, D2, D3

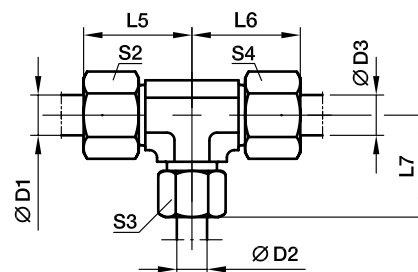
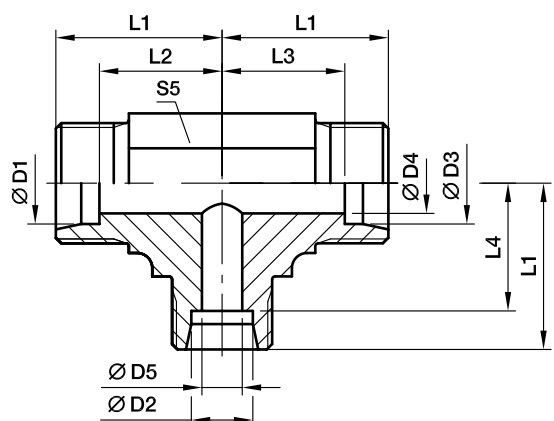
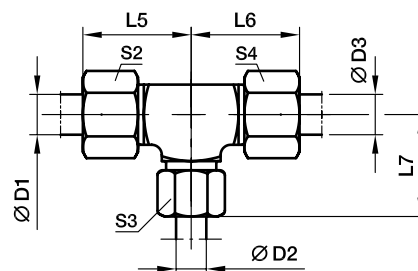
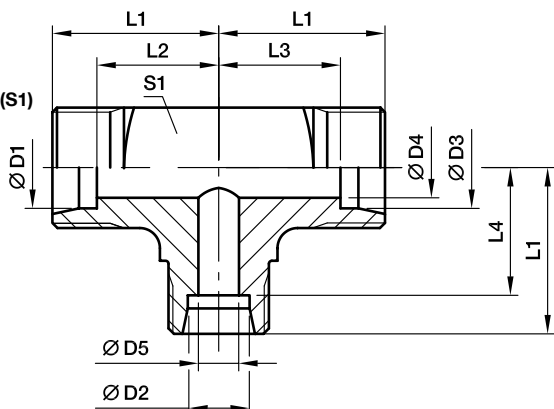

Szereg	D1	D2	D3	D4	D5	L1	L2	L3	L4	L5	L6	L7	S1	S2	S3	S4	S5	Ciężar g/szt.	Kod zamawiania*	PN (bar) ¹⁾		
	Ø	Ø	Ø																	CF	71	MS
LL ²⁾	04	08	04	3.0	6	17	13.0	13.0	11.5	23	23	23	12	10	14	10	12	27	TR04/08/04LL	100	100	63
	06	04	06	4.5	3	15	9.5	9.5	11.0	21	21	21	11	12	10	12	9	18	TR06/04/06LL	100	100	63
L ³⁾	06	08	06	4.0	6	21	14.0	14.0	14.0	29	29	29	14	14	17	14	12	54	TR06/08/06L	500	315	200
	08	06	08	6.0	4	21	14.0	14.0	14.0	29	29	29	14	17	14	17	12	53	TR08/06/08L	500	315	200
	06	10	06	4.0	8	22	15.0	15.0	15.0	30	30	30		14	19	14	14	53	TR06/10/06L	500	315	200
	08	10	08	6.0	8	22	15.0	15.0	15.0	30	30	30		17	19	17	14	50	TR08/10/08L	500	315	200
	10	06	10	8.0	4	22	15.0	15.0	15.0	30	30	30		19	14	19	14	46	TR10/06/10L	500	315	200
	10	08	10	8.0	6	22	15.0	15.0	15.0	30	30	30		19	17	19	14	43	TR10/08/10L	500	315	200
	10	10	06	4.0	8	22	15.0	15.0	15.0	30	30	30		19	19	14	14	49	TR10/10/06L	500	315	200
	08	12	08	6.0	10	24	17.0	17.0	17.0	32	32	32		17	22	17	17	67	TR08/12/08L	400	315	200
	12	06	12	10.0	4	24	17.0	17.0	17.0	32	32	32		22	14	22	17	66	TR12/06/12L	400	315	200
	12	08	08	6.0	6	24	17.0	17.0	17.0	32	32	32		22	17	17	17	66	TR12/08/08L	400	315	200
	12	08	12	10.0	6	24	17.0	17.0	17.0	32	32	32		22	17	22	17	68	TR12/08/12L	400	315	200
	12	10	10	8.0	8	24	17.0	17.0	17.0	32	32	32		22	19	19	17	67	TR12/10/10L	400	315	200
	12	10	12	10.0	8	24	17.0	17.0	17.0	32	32	32		22	19	22	17	67	TR12/10/12L	400	315	200
	12	12	10	8.0	10	24	17.0	17.0	17.0	32	32	32		22	22	19	17	64	TR12/12/10L	400	315	200
	10	15	10	8.0	12	28	21.0	21.0	21.0	36	36	36		19	27	19	19	105	TR10/15/10L	400	315	200
	12	15	12	10.0	12	28	21.0	21.0	21.0	36	36	36		22	27	22	19	102	TR12/15/12L	400	315	200
	15	06	15	12.0	4	28	21.0	21.0	21.0	36	36	36		27	14	27	19	107	TR15/06/15L	400	315	200
	15	10	15	12.0	8	28	21.0	21.0	21.0	36	36	36		27	19	27	19	105	TR15/10/15L	400	315	200
	15	12	12	10.0	10	28	21.0	21.0	21.0	36	36	36		27	22	22	19	101	TR15/12/12L	400	315	200
	15	12	15	12.0	10	28	21.0	21.0	21.0	36	36	36		27	22	27	19	105	TR15/12/15L	400	315	200
	15	15	12	10.0	12	28	21.0	21.0	21.0	36	36	36		27	27	22	19	103	TR15/15/12L	400	315	200
	12	18	12	10.0	15	31	24.0	24.0	23.5	39	39	40		22	32	22	24	177	TR12/18/12L	400	315	200
	18	10	10	8.0	8	31	23.5	24.0	24.0	40	39	39		32	19	19	24	173	TR18/10/10L	400	315	200
	18	10	18	15.0	8	31	23.5	23.5	24.0	40	40	39		32	19	32	24	182	TR18/10/18L	400	315	200
18	12	18	15.0	10	31	23.5	23.5	24.0	40	40	39		32	22	32	24	174	TR18/12/18L	400	315	200	

TR Złączka trójkątna redukcyjna

Końcówki EO ze stożkiem 24°

Szereg	D1	D2	D3	D4	D5	L1	L2	L3	L4	L5	L6	L7	S1	S2	S3	S4	S5	Ciężar g/szt.	Kod zamówienia*	PN (bar) ¹⁾		
																				CF	71	MS
L ³⁾	18	15	18	15.0	12	31	23.5	23.5	24.0	40	40	39		32	27	32	24	179	TR18/15/18L	400	315	200
	18	18	10	8.0	15	31	23.5	24.0	23.5	40	39	40		32	32	19	24	171	TR18/18/10L	400	315	200
	22	10	22	19.0	8	35	27.5	27.5	28.0	44	44	43		36	19	36	27	232	TR22/10/22L	250	160	100
	22	12	22	19.0	10	35	27.5	27.5	28.0	44	44	43		36	22	36	27	229	TR22/12/22L	250	160	100
	22	15	15	12.0	12	35	27.5	28.0	28.0	44	43	43		36	27	27	27	240	TR22/15/15L	250	160	100
	22	15	22	19.0	12	35	27.5	27.5	28.0	44	44	43		36	27	36	27	233	TR22/15/22L	250	160	100
	22	18	18	15.0	15	35	27.5	27.5	27.5	44	44	44		36	32	32	27	236	TR22/18/18L	250	160	100
	22	18	22	19.0	15	35	27.5	27.5	27.5	44	44	44		36	32	36	27	239	TR22/18/22L	250	160	100
	22	22	18	15.0	19	35	27.5	27.5	27.5	44	44	44		36	36	32	27	228	TR22/22/18L	250	160	100
	28	10	28	24.0	8	38	30.5	30.5	31.0	47	47	46		41	19	41	36	412	TR28/10/28L	250	160	100
	28	12	28	24.0	10	38	30.5	30.5	31.0	47	47	46		41	22	41	36	408	TR28/12/28L	250	160	100
	28	15	28	24.0	12	38	30.5	30.5	31.0	47	47	46		41	27	41	36	423	TR28/15/28L	250	160	100
	28	18	28	24.0	15	38	30.5	30.5	30.5	47	47	47		41	32	41	36	421	TR28/18/28L	250	160	100
	28	22	22	19.0	19	38	30.5	30.5	30.5	47	47	47		41	36	36	36	412	TR28/22/22L	250	160	100
	28	22	28	24.0	19	38	30.5	30.5	30.5	47	47	47		41	36	41	36	415	TR28/22/28L	250	160	100
	S ⁴⁾	10	06	10	7.0	4	25	17.5	17.5	18.0	34	34	33		22	17	22	17	103	TR10/06/10S	800	630
12		08	08	5.0	5	29	21.5	22.0	22.0	38	37	37		24	19	19	17	107	TR12/08/08S	630	630	400
12		08	12	8.0	5	29	21.5	21.5	22.0	38	38	37		24	19	24	17	105	TR12/08/12S	630	630	400
12		10	12	8.0	7	29	21.5	21.5	21.5	38	38	38		24	22	24	17	114	TR12/10/12S	630	630	400
12		16	12	8.0	12	33	25.5	25.5	24.5	42	42	43		24	30	24	24	190	TR12/16/12S	630	400	250
16		06	16	12.0	4	33	24.5	24.5	26.0	43	43	41		30	17	30	24	176	TR16/06/16S	630	400	250
16		08	16	12.0	5	33	24.5	24.5	26.0	43	43	41		30	19	30	24	208	TR16/08/16S	630	400	250
16		10	16	12.0	7	33	24.5	24.5	25.5	43	43	42		30	22	30	24	210	TR16/10/16S	630	400	250
16		12	16	12.0	8	33	24.5	24.5	25.5	43	43	42		30	24	30	24	386	TR16/12/16S	630	400	250
16		20	16	12.0	16	37	28.5	28.5	26.5	47	47	48		30	36	30	27	296	TR16/20/16S	420	400	250
20		10	20	16.0	7	37	26.5	26.5	29.5	48	48	46		36	22	36	27	553	TR20/10/20S	420	400	250
20		12	20	16.0	8	37	26.5	26.5	29.5	48	48	46		36	24	36	27	306	TR20/12/20S	420	400	250
20		16	20	16.0	12	37	26.5	26.5	28.5	48	48	47		36	30	36	27	285	TR20/16/20S	420	400	250
20		25	20	16.0	20	42	31.5	31.5	30.0	53	53	54		36	46	36	36	544	TR20/25/20S	420	400	250
25		16	25	20.0	12	42	30.0	30.0	33.5	54	54	52		46	30	46	36	556	TR25/16/25S	420	400	250
25		20	25	20.0	16	42	30.0	30.0	31.5	54	54	53		46	36	46	36	544	TR25/20/25S	420	400	250
25	30	25	20.0	25	49	37.0	37.0	35.5	61	61	62		46	50	46	41	791	TR25/30/25S	420	400	250	

1) Jeśli w tabeli podano wartość ciśnienia, wyrób jest w aktualnej ofercie.

2) LL = szereg bardzo lekki; 3) L = szereg lekki; 4) S = szereg ciężki

$$\frac{PN(\text{bar})}{10} = PN(\text{MPa})$$

Dostawa bez nakrętki i pierścienia. Informacje o zamawianiu kompletnych łączników - patrz strona 17.

Przyrostki w kodzie zamówienia		
Materiał	Przyrostek oznaczający rodzaj powierzchni i materiał	Przykład
Stal ocynkowana, bez chromu Cr(VI)	CF	TR16/12/16SCFX
Stal nierdzewna	71	TR16/12/16S71X
Mosiądz	MS	TR16/12/16SMSX

*W zależności od żądanego materiału i pokrycia powierzchni do kodu należy dodać jeden z poniższych przyrostków.